

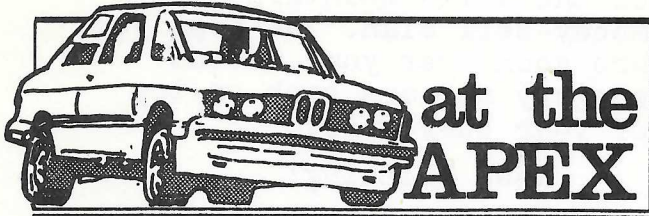

Das Kummer

april 1983



CHARLES DICKENS

Our Anniversary Rally turned out over 30 BMW's and Porsches, and over 70 for dinner at the Red Lobster. The course was great and Rallymiesters Nathan Segal and Jeff Barnett even had a set of Burma Shave signs near the end which gave reassurance to drag-ins like me that we were still on the trail after all.

Jeff and Nathan got a surprise at award time in the form of a New Club Award, the PRESIDENT'S SPARK PLUG AWARD. This consists of a handsom hand crafted walnut plack with a spark plug at the top, a brass plate with suitable inscription and at the bottom a BMWCCA grill badge. These were not awarded for ramrodding the rally,perse, but because these two guys carry a large share of the work load of running Bey Em Vey and I, as President, felt that they were over due for a little recognition for the fine jobs they do. Thanks a bunch guys - now, for your next assignment ----. One other interesting thing that developed was that a lot of Bey Em Veyers seem to be interested in rallying. To quote our activities person, Krist Jani, "very interesting." In addition to the Rally on.

cont. pg 2

KRIST JANI

Bey Em Vey
Activities

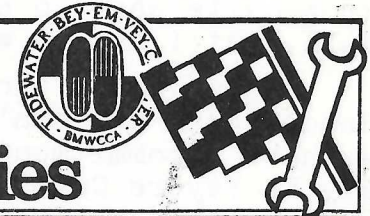

MAY 1-DEADLINE Rendezvous Registration

May 1st - Sunday - 5:00PM -
Members Meeting at Nathan
and Debbie Segal's home at
3949 Wilmington Rd., Va Beach
(Green Run Area) call
467-9777 - We'll be making
final Blue Ridge Rendezvous
Plans.

May 14th - Saturday - 318 I TECH
10AM to 3PM ATLANTIC BMW will
present a Technical Session on
the 1984 318I. We will have a
Car displayed so that you all
can see it in complete detail,
top, bottom and sides. We
will also have a five speed and
an automatic for demonstration
drives. As always refreshments
will be provided and our Parts
Department will be open and
will feature the Mark Aldridge
"Whopper" discount. Remember in
1984 there will only be two
types of drivers....those who
drive the 318I and those who
wish they did!

May 28th,29th,30th - Sat.-Mon. -
BLUE RIDGE RENDEZVOUS -
Smith Mountain Lake - Please
Plan to attend - see flyer
and order form attached.
Call 424-4248 or 489-7501
and ask me for details.

cont. pg 2

Blue Ridge **RENDEZVOUS**

MEMORIAL DAY WEEKEND
May 28 - 29 - 30, 1983

APEX

the Blue Ridge Rendezvous we are already planning for a Fall Rally, as a matter of fact, Nathan was heard mumbling to himself something about how many ways you can get across the Chesapeake Bay and Jeff was asking me if BMW's float so I don't know quite what to expect this Fall, but I bet it will be fun.

Speaking of the Blue Ridge Rendezvous, and don't I love to, we have a commitment from former Bey Em Veyers Carolyn and Lloyd Prince who now live in the Hinterlands of Florida where there isn't even a BMWCCA chapter. Also some of Krist Jani's former cohorts from the Allegheny Chapter in Pennsylvania will be coming down and will pick up some of their running mates from the Mountain State Chapter, West Virginia. We have 15 motel rooms at the site and a camp ground with all the comforts of home, plus a marina, a swimming pool and Smith Mountain Lake at our disposal. There will be a very good Blue Grass Band, The Virginia Mountain Boys, to furnish a lot of Mountain Music and some of the best bull shooting on the East Coast. Damn, I can hardly wait.

Somewhither in this very issue of Das Kummert there is a registration blank for the Blue Ridge Rendezvous. Find it. Remove it. Fill it out completely. Mail it, along with a check to Linda Dickens, 608 Apache Rd., Portsmouth, VA 23701. If you have any questions or for that matter any answers call Krist Jani or my humble self. Best time for calling me is about 9:00AM or at midnight. Home 488-0030. If necessary you may call me at work 804-562-2161 from 3:00PM until 11:00 PM Tuesday through Saturday.

If you want a piece of the Blue Ridge Rendezvous but have a spouse at sea or some other ify situation, sign up and pay

up and if your plans fall through we will refund your investment but I fear that it will do very little good to call after the May 1st deadline to try to sign up. Deadline is a very apt word.

Bey Em Vey Corp. sends our best wishes for a swift and complete recovery to Robin Moody of the Smith Mountain Lake Moody-Bell clan. We hope you are soon over your recent surgery and are back on top of your busy world.

Keep Blinking!

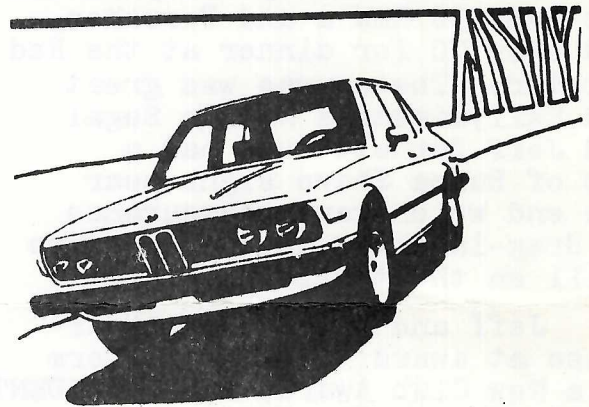

Bey Em Vey Activities

- June 5th - Sunday - 5:00 PM - Membership Meeting - location to be announced.
- June 12th - Sunday - 12:00 Noon - Tech Session - Paul Hobson's home at 3564 Good Hope Rd. (off of Rosemont Rd.) call 486-7542.
- July 9th and 10th - Saturday and Sunday - Atlantic Zone Congress - C'ville or Richmond details to follow.



VEEP NOTES

NATHAN SEGAL

"A Roaring Success." Those were the words to describe our Anniversary Rally. The weather was beautiful and the turnout was super. We had 30 cars from our club and the Porsche Club. It was quite a sight to see! The course was challenging to many and the dinner afterward capped off a day that can only be describes as Fantastic!

Due to a snafu, 1st place went by mistake to a Porsche. We discovered the error minutes later and corrected it later by awarding two 1st Place Prizes. The winners were as follows:

- 1st Prize-Paul Hobson, BMW 2000 CS.
- 1st Prize-(but really second) Bert and Diane Turnure, Porsche 911S.
- 2nd Prize-Larry and Debbie Thomase, Porsche 924 Turbo.
- 3rd Prize-George Olde and Elise Argue, BMW 533i.
- 4th Prize-Becky Barnett and Debbie Segal, BMW320i.
- 5th Prize-Jerry Restaino and Julliette Rosso, BMW 2002.
- 6th Prize-Bruce Groremann and Ed Strazzini, Porsche 911SC.
- 7th Prize-Mike Farelli and Beth Evans, BMW 2002.

To all of the Winners, CONGRATULATIONS! My special Thanks to Atlantic BMW, who gave us an extra oil change for a prize and to Neil Chadwick of Chadwicks Custom Car Care who really came through in a pinch and donated another 10 point restoration for the added 1st place.

Now, to the losers; our last Place Prize (the ever popular Club Curb Feelers) went to Krist Jani and his navigator B.J. While the winners answered 67 of the 70 questions correct, Krist came

in with 54 correct. For those who want some rally trivia, the course was 65 miles long. The best mileage with all of the questions answered was our own Jerry Restaino and Julliette Russo in the UCA BMW 2002. Their mileage was 67.5 miles. We had only one bail out. It occurred when driving on Shore Drive you were instructed to make a right on 279 or at Clydes. That would put you on Great Neck Road. One BMW 320i missed that turn and stayed straight, when they arrived at the resort strip they bailed out. Thanks to all who participated. There will be another Porsche-BMW Rally in September or October, so please be ready for it.

Now for the Blue Ridge Rendezvous, I hope to see all of you there as it will be our best yet. Debbie and I are avid fresh water fisherpersons, so if any members are the same, please give us a call so that we can coordinate boat rentals at Smith Mountain Lake.

Till the Blue Ridge, Keep Blinking!

President	
CHARLES DICKENS	488-0030
Vice President	
NATHAN SEGAL	467-9777
Secretary	
RUSTY BARTON	495-2728
Treasurer	
LINDA DICKENS	488-0030
Activities Chairman	w.489-7501
KRIST JANI	h.424-4248
Penninsula Coordinator	
BILL WARD	1-229-9615
Tips Representative	
HUGH WELLS	919-743-1601
Newsletter	
BARNETTS & SEGALS	340-9043

BLUE RIDGE
Rendezvous

MAY 28,29,30

DX

JIM ATWELL

We have all sorts of news, mostly good, for this month's Dealer Exchange.

Beginning April 1, Atlantic BMW will provide additional support to BMWCCA members by offering a 10% discount on the parts portion of a repair order in our Service Department. This new discount is subject to the same rules as our long standing over the counter Parts Discount of 10%. The two discounts are separate and distinct. They cannot be combined or made cumulative in any way.

Our Sales force has been enlarged by 1 new salesperson. Elise Argue, formerly with WFOG, has joined us up front. Elise has considerable sales experience in the advertising area and has already completed BMW NA's Buyer's Motivation Workshop. We are delighted to have Elise with us and look forward to great things from her.

We've also added a new face in our Service Department. Terry Baker, formerly Heishman BMW's top wrench and of late from MCM in Sparks, Nevada now occupys one of our Service bays. Terry is a first class BMW trained technician, a race car builder/driver, a Cannonball participant (1979) and a Willy Nelson fan. "Honk if you Love Willy Nelson". Terry is one of the Good Guys and a truly talented wrench. I had the pleasure of working with him at Heishman's for 3 years and I'm very pleased that he decided to join us a ABMW.

ATLANTIC BMW was well represented at the Chapter Rally on March 20th. Larry Burgess, along with his wife Andrea and their two lovely daughters, made the run in our Henna Red "S". They ran somewhere in the middle after deciding that Wendy's sold the Nitrate of

Chile?? Joe Libby and his two sons also finished in the middle driving an older 2002. They were the first arrival at the finish line. Elise, our new salesperson accompanied our latest customer, George Olde, in his spanking brand new Gorgeous Graphite/pearl leather 533I (two days old) and they did a terrific job! The first of our BMW's in a solid 3rd place overall just behind two brand X competitors from PCA. I enjoyed a solo ride (my wife and children refused to ride with me and I was unable to steal BJ away from Krist Jani) in a new 528 EA and finished out of the money. We all had a great afternoon and we offer a vote of thanks for a super event to Nathan Segal and Jeff Barnett. They did an outstanding job!! Well Done!!

At this writing our supply of 320I's is exhausted. We are eagerly awaiting the arrival of our first 1984 318's during the first week in May. We have been pre-allocated eight of these cars thus far and expect at least twice that many during the month of May. Please come by for a visit and a test drive as soon as possible! Meantime we have an adequate supply of 5,6, and 7 Series cars.

The 318I will have it's U.S. premier May 3 thru 7 at the Hyatt Maui in Hawaii. Our owner Gene Meakins has graciously declined to go and has ordered me to attend in his stead. Life is tough at Hilltop! Jeanne, Kate and Jenny are already packed and will accompany me. We're looking forward to a fun time and an opportunity to meet with all our friends from BMWNA. We'll have a trip report for you all on our return.

Our wrenches Dean, Wyndham and Terry already BMWNA school trained will all be attending a two day training session at

THE CAR THAT TRANSLATES HIGH TECHNOLOGY INTO HIGH PERFORMANCE.

Thanks to a microprocessor-assisted engine, a new breakthrough in rear-suspension design, and the new BMW Service Interval Indicator, the BMW 528e is a luxury car that literally thinks its way to higher performance.

To experience it, contact us for a thorough test drive.



THE ULTIMATE DRIVING MACHINE.
BMW, MUNICH, GERMANY.

BMW
528e



© 1982 BMW of North America, Inc. The BMW trademark and logo are registered trademarks of Bayerische Motoren Werke, A.G.

ATLANTIC BMW
1829 Laskin Road, Virginia Beach, Va. 23454
(804) 422-3201

DX

Montvale on the new 318I.
Dean will go first May 4th and
5th. Wyndham and Terry will
follow as soon as quotas are
received.

Our motorcycle ride "1000
in 1" is temporarily stalled as
we await the arrival of two new
Bing carbuerators and some warmer
weather.

Charles "Prez" Dickens and
I will be checking out the Blue
Ridge Rendezvous rally route in
April. Larry Burgess wanted to
go along but the three of us
present a weight and balance
problem for anything less than
a Kenworth. With these two
around I stop worrying about my
diet!

For those of you with body
problems (aside from Charles and
Larry) we are now stocking sheet
metal parts such as fenders, hoods,
deck lids and doors. Call Mark
or Peggy in parts for assistance
on these items.

In order to provide better
service to our customers we are
planning to expand our Service
Department hours by opening on
Saturday and perhaps one evening
a week. Keep an eye out for our
new schedule, soon to be pub-
lished. We are also planning to
get ready for a beautiful BMW
summer. More on all this soon.

That's about it for now.
I'm off to Georgia in the morning
for a one-day 318I tech session
hosted by Chris Motors and SE
Region BMWNA. Incidentally we
are now being supported by SE
Region out of the port of
Jacksonville Florida and thus
far the support has been out-
standing.

Drop in for a visit soon.
Our welcome mat is always out!

TECH TIPS

ELECTRICAL MAGIC

Mighty Red/Charles Dickens

Many and varied are the prob-
lems which arise from a fuse box
that has not been maintained. I
could not for the life of me
keep all four of my headlights
functioning properly. Finally
I removed all of the fuses and
with a piece of fine grit sand
paper, cleaned the fuse holders.
I then gently bent them in so
that they would hold the fuses a
little more snugly. I then re-
placed the old fuses with new,
copper fuses, copper, I said.
To make this problem area as
bullet proof as possible I
anoointed the fuse holders and
the ends of the new copper
fuses with ML2X, an Ecklin
product. This 7 inch tube costs
about \$15.00 and came highly
recommended by a four wheel
drive friend of mine whose
credentials are impeccable.

This silicone based dres-
sing promotes good electrical
contact and keeps the air off
of these metal parts and thus
prevents corrosion. A tube
should last about a normal
lifetime and so it is a good
value. I apply this dressing
with a Q tip.

While I'm telling everything
I know about electrical gizmos,
I may as well get this one off
of my chest as well. My electric
air horns had gone intermittant
on me and then died completely.
I also had an unrelated whine in
my radio which varied with engine
speed and was, no doubt, coming
from my alternator. I checked
out my horn equipment and found
that the relay was relaying
and the juice was getting to the
compressor - but the compressor
was not compressing. I un bolted
the mounting bolts, one of which
had doubled as the ground for
the unit. I never was satisfied
with this when I installed it but

cont. pg 7

more TECH TIPS

it worked and I forgot about it. I cut off the small eyelet with which the ground wire was equipped and replaced it with a larger eyelet which would fit on the ground screw along with a bunch of other wires on the edge of the battery tray. On my car the battery tray is missing and the bunch of wires are now bolted to the place where the battery box was. I removed this bolt revealing some very dubious looking electrical contacts. I cleaned these with a new piece of fine grain sand paper and then sanded the spot on the fender until I was looking at bare metal. I then dressed this 3/4 square inch of naked BMW with my magic electrical dressing, dressed the various ends to be grounded and reassembled them to the fender. The air horns worked and the unreleated radio noise was gone. Have Mercy! It's enough to make me want to do lots of small, cheap but very rewarding, maintenance jobs on my BMW.

GEAR SHIFT LEVER NOISE

Blue Ridge Chapt.

A rattling noise may be heard under load above 4500 RPM through the gear shift lever on 1982 320i vehicles equipped with a five-speed transmission.

This condition may be corrected by installing four shims, part number 25 11 1 220 439, and tow clips, part number 25 11 1 220 379 which are available from the BMW of North America Parts Department. The rubber thrust washer, part number 23 41 1 466 118, which is inserted into the gear selector rod joint should be black and 8.5mm thick. If the rod joint is supplied or equipped with the thinner 7.5mm white rubber washer, replace it with above mentioned black rubber washer. If the black

8.5mm washer is not available, use two (2) 7.5mm white rubber washers slicing one in half and combining this half with another uncut washer. When installing the washer, use a small amount of grease to act as a lubricant.

After completing the repair procedure, remove the gear shift lever knob emblem and fill the knob with sealing compound (Dum-Dum), part number 81 22 9 400 018. This will increase the weight of the shift knob and absorb any transmitted vibrations. Replace the emblem after the knob has been filled.

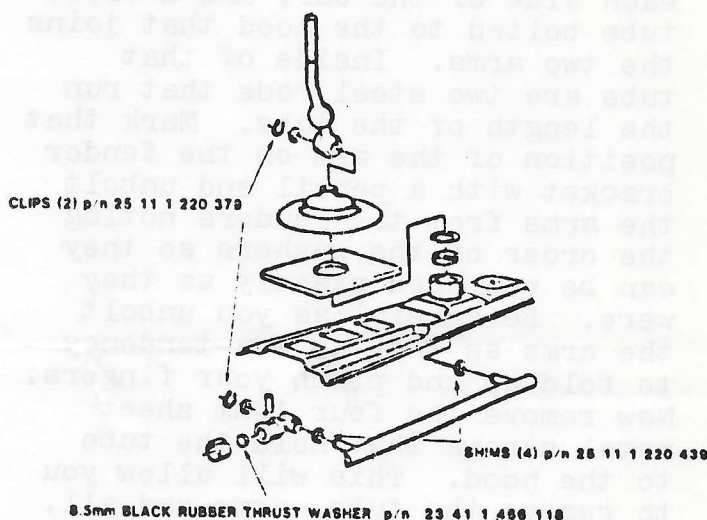

ALLOY WHEEL TORQUE

BILL MACHRONE
(NEW JERSEY CHAPTER)

BMWNA has changed the torque specifications for all cars with wheel bolts (not lug nuts). This includes both steel and alloy wheels. The factory now specifies at torque of 65 to 80 foot-lbs. The service bulletin also reminds dealers to follow the proper procedure of tightening the bolts diagonally to ensure proper installation.

The proper torque for cars with wheel nuts is unchanged at 59-65 foot-lbs, again for both steel and alloy wheels.

& more TIPS

For Your Information

STICK IT TO YOUR BAVARIA

MIKE CINNAMON
(BOSTON CHAPTER)

If your Bavaria engine compartment hood won't stay open and you refuse to drill holes like the Tech article in the Roundel said, follow me... First, prop open the hood with a stick (I know it sounds tacky but it is only temporary). Notice that the hood holding mechanism is made of two folding arms, one on each side of the car, and a cross tube bolted to the hood that joins the two arms. Inside of that tube are two steel rods that run the length of the tube. Mark that position of the arm on the fender bracket with a pencil and unbolt the arms from the fenders noting the order of the washers so they can be replaced exactly as they were. Be careful as you unbolt the arms as they have a tendency to fold up and pinch your fingers. Now remove the four 10mm sheet metal screws that hold the tube to the hood. This will allow you to remove the tube, arms and all, from the hood.

Now notice how one of the rods that comes out of the tube is bent at a right angle and is held in place by a block. If you remove this block you will notice it is worn where the rod makes contact with it. The fix is to swap the block on the left side of the tube with the block on the right side. The rods wear out the opposite sides of the block so this is just like putting in new blocks.

Put the tube back in place and bolt the arms back to the fender in the same place as before and burn the stick.

RENDEZVOUS

BMWCCA ROADRUNNER CHAPTER

1982-83 BMW 528e. In some cars, a bolt that supports the rear of the differential may have been overtightened, which may cause the nut to crack. That could cause a vibration and rattling in the rear axle area; eventually, the rear axle could come loose and contact suspension, causing difficulty maintaining control. Models: 1347 1982-83 BMW 528e cars made from July through September 1982. Return car to dealer for inspection and, if necessary, replacement of hardware.

1983 BMW 528e, 533i, and 633CSi. In some cars, certain steering column fasteners may come loose, causing loss of steering and a possible crash. (Driver would probably have advance warning through excessive play in steering.) Models: 1012 BMW 528e, 533i and 633 CSi cars made from September through November 1982. Return car to dealer for proper fastening.

Classified Ads

FOR SALE: Weber Carburetors, 32/36 DGAV kit for 2500/2800/3.0, Bavaria, CS. Slightly used, excellent condition. (Includes installation) \$450 or best offer. Call: Jim Craig
397-6917 (after 7PM)

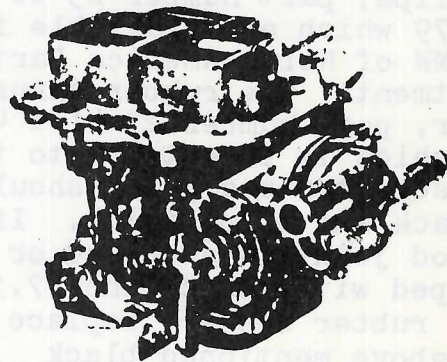



CLUB DISCOUNT for MAIL ORDERS

(Except dealer-only items)

The **KORMAN
AUTOWORKS CATALOG**
64 PAGES! **\$3.50**

Featuring:

PERFORMANCE EQUIPMENT AND ACCESSORIES,

including Supersprint exhausts,
Korman headers, Recaro seats,
Bilstein and Carrera shocks,
Bosch electrics, Cibie, Hella and
Marchal lights, Momo, BWA and
Sportmark steering wheels,
Momo, BBS, Alpina, Ronal and
Compomotive road wheels,
Kamei, Ronal, and Zender
spoilers, Weber carb kits, Alpina
engine parts,

Korman turbo-chargers,
Phoenix Stahlflex tires, Ferodo
brake pads, Korman and Alpina
suspension systems, BMW
original equipment parts.

ENGINE REBUILDING Full
specs, prices, dyno charts from
stock to full race options.

COMPETITION EQUIPMENT
All the trick stuff!

Caring for your BMW

We ship engines, parts, and accessories throughout North and South America. For BMW owners within driving distance, we offer professional service and repairs for your BMW. Our expanded staff includes fully qualified mechanics with BMW/NA training, community college automotive education and National Institute of Automotive Service Excellence Certification. Our SERVICE DEPT. is equipped with the SUN COMPUTER II DIAGNOSTIC TESTER, appropriate Bosch fuel injection test equipment and all necessary BMW special tools.
For a routine tune up or major overhaul, we have the expertise to provide the best care for your BMW.

Introducing new and better IGNITION WIRES and FREE FLOW EXHAUSTS

■ **New KORMAN IGNITION WIRES**

Custom sets. Ultra-high temperature silicone jacket. Shielded wire core. No radio noise. Improved spark conductivity.

All 4 Cylinder **\$29.95** All 6 Cylinder **\$39.95**

■ **PRIMA-FLOW EXHAUST SYSTEMS**

Dyno test comparisons prove Prima-Flow produces more horsepower at quieter noise levels than Supersprint or Ansa. Most BMW models available.

■ **RECARO SEATS** — *Special club discount.*

For **SERVICE** call 919/273-9604

For **MAIL ORDER PARTS** call or write 919/275-1494

1316 HEADQUARTERS DR., GREENSBORO, NC 27405

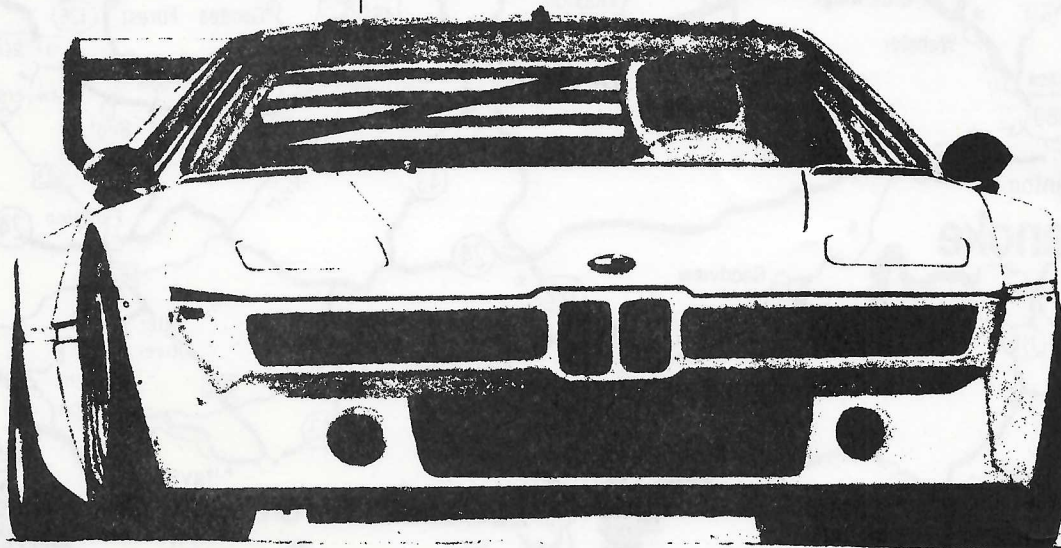

BLUE RIDGE RENDEZVOUS

MEMORIAL DAY WEEKEND
May 28 - 29 - 30, 1983

BMWCCA PLANNED ACTIVITIES:

SATURDAY

- Afternoon Lake Activities
- Vehicle Safety Check
- Group Dinner (From Menu)
- General Meeting

SUNDAY

- Brunch
- Road Rally
- "Pig Pie" Barbeque (with Bluegrass Band)
- Awards Presentation

ACCOMODATIONS AVAILABLE:

- Motel with pool
- Camping with facilities
- Cabins -Off Site

LAKE ACTIVITIES AVAILABLE:

- Smith Mt. Lake Dam Tour
- Boating - Hiking
- Fishing - Swimming
- (Boat rentals available)

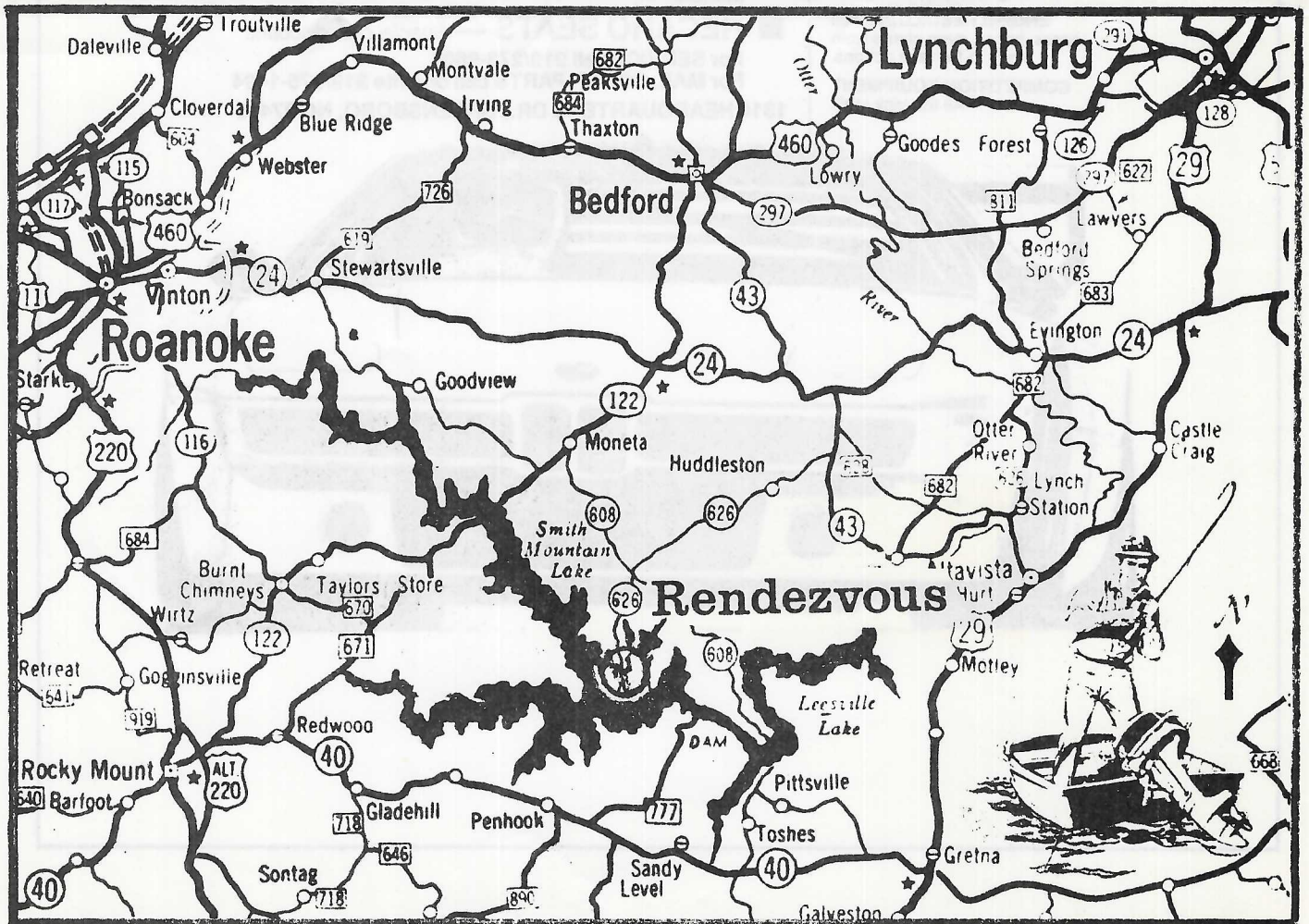

MEMORIAL DAY WEEKEND
May 28 - 29 - 30, 1983

BLUE RIDGE RENDEZVOUS

Join the
Tidewater Chapter
at Smith Mountain Lake near
Lynchburg, Virginia in the beautiful

Blue Ridge Mountains for three days of driving,
boating, hiking, fishing, and relaxing on Memorial Day Weekend,
May 28 - 30 . Planned activities include a Road Rally, Dinner, Pig Pickin', Safety Check,
Meeting, Brunch and Lake activities. Package Plans: A. Two nights motel, events - \$125.00 per
couple. B. Two nights motel, events - \$100.00 single. C. Camping, events - \$50.00 per couple.
D. Day events only - \$35.00 single. All packages include insurance and all club events, except
Saturday Dinner. Deadline for reservations is May 1, 1983. Send checks to Bey Em Vey, P. O. Box
62145, Va. Beach, VA 23462. Contact Charles Dickens (804) 488-0030 or Krist Jani (804) 489-7501
for further information.

Chapters from at least four states will be represented.
Let's make the Rendezvous second only to O'Fest!



BEY EM VEY CORP.
TIDEWATER CHAPTER, BMWCCA
P.O. BOX 62145, VIRGINIA BEACH, VA 23462

BLUE RIDGE RENDEVOUS REGISTRATION FORM
MAY 28-29-30, 1983

DEADLINE MAY 1, 1983

NAME _____ CHAPTER _____ MEMBERSHIP # _____
NAMES OF ALL SPOUSES, CHILDREN, OR OTHER HANGERSON WHO WILL ATTEND WITH YOU.

HOME ADDRESS _____

HOME PHONE # _____ WORK PHONE # _____

KIND AND MODEL CAR YOU PLAN TO DRIVE IN RALLY? _____ WHY? _____

ANY OTHER INPUT? _____

- CHECK ENCLOSED FOR HOW MUCH? _____ MAIL TO:
- FULL WEEKEND
 - FULL WEEKEND CAMP OUT
 - SUNDAY MAY 29 ACTIVITIES ONLY
 - OTHER ? _____

LINDA DICKENS
608 APACHE RD.
PORTSMOUTH, VA. 23701

ANY QUESTIONS OR ANSWERS CALL KRIST JANI AT 804-424-4248 OR CHARLES DICKENS 804-488-0030

Material appearing in "DAS KUMMET" may be reprinted without permission provided proper credit is given.

"DAS KUMMET" is a monthly publication of the Tidewater Chapter (Bey Em Vey Corporation of the BMW Car Club of America, Inc.) and is provided by and for the members of the BMW Car Club of America only. The ideas, opinions and suggestions expressed in regard to technical matters are those of the authors, and no authentication is implied by the editor or publishers. Modification within the warranty period may void the warranty.

The Tidewater Chapter (Bey Em Vey Corporation) of the BMW Car Club of America Inc. is an independent group of BMW owners and is not associated with the manufacturer, importer, or dealers of BMW automobiles. Meetings are held as announced in this publication.

Send your check for \$25.00 made payable to BMWCCA to the above address of Bey Em Vey Corp. This covers a year's membership in the local and national club.

Signature _____

Serial No. _____

Serial No. _____

BMW No. 2 _____ Year _____

Model of BMW _____ Year _____

Zip _____ Phone _____

City _____ State _____

Address _____

Name _____

MEMBERSHIP APPLICATION
Bey Em Vey Corporation
Box 62145
Virginia Beach, Virginia 23462

BEY EM VEY CORP.
P. O. BOX 62145
VA. BEACH, VA. 23462

ADDRESS CORRECTION REQUESTED



1121:8212:7
JOHN BARTON
1636 JAMESON DR
VA BEACH VA 23464